

APR 1200

Acoustic Partition Roll

Glass mineral wool roll designed to provide high levels of sound insulation in walls and floors to meet Part E (England & Wales) and Section 5 (Scotland) acoustic requirements.



Description

ISOVER APR 1200 is a non-combustible glass mineral wool roll for sound insulation in partitions, walls and floors.

The product provides a strong, resilient and flexible insulating mat, which is easy to cut, handle and install and will not slump under its own weight when suspended vertically.

Durability

- Made from rot-proof non-hygroscopic materials.
- Will not accelerate corrosion with steel, copper or aluminium.
- Will not sustain vermin, nor breed or promote fungi or bacteria.

Ecological Information

ISOVER APR 1200 products are made from glass mineral wool, one of the most environmentally friendly insulants available.

Sustainable

ISOVER APR 1200 products are manufactured from silica sand, the earth's most abundantly occurring mineral and a sustainable, infinite resource.

Recyclable

Approximately 80% of the raw material used in the production of ISOVER APR 1200 products is recycled, far more than any comparable product. The recycled material can be post-consumer glass (from housing generation projects) or waste glass from bottle and flat glass manufacture, which would otherwise go to landfill.

Environmental

The manufacturing process does not use or contain CFC's, HCFC's or other damaging gases - nor has it ever. In addition, the unique resilience of ISOVER glass mineral wool enables high compression packing which means more insulation in a

smaller space than almost any other insulant. The result is better vehicle utilisation, reducing the environmental impact of transportation.

EcoHomes/Sustainable Homes

ISOVER APR 1200 products achieve full credit under EcoHomes performance for zero Ozone Depletion Potential (ODP) and a Global Warming Potential (GWP) of less than 5.

Benefits

- Meets Part E Building Regulations for internal walls and floors and party wall and floors
- Guaranteed lifetime performance as part of the British Gypsum SpecSure™ system warranty
- Good thermal performance
- Easy to install
- Excellent fire performance
- Long product life - will not age
- Fully compatible with all standard building materials and components

Standards



ISOVER APR 1200 is manufactured under a BSI Quality Assurance Scheme in accordance with BS EN ISO 9001:2000

ISOVER APR 1200 is the only acoustic insulation quilt fully tested and approved for use with British Gypsum drywall systems covered by the SpecSure® Lifetime Performance Warranty



Acoustic Performance

Internal Partitions

Part E Building Regulations July 2003 calls for minimum 40dB airborne sound insulation in imperforate internal partition walls. The following constructions incorporating ISOVER APR 1200 will comply with this requirement.

Timber Stud Partitions

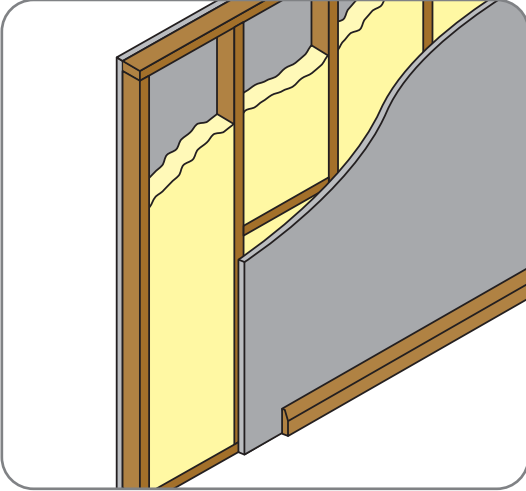

A partition wall constructed from 1 layer of 12.5mm Gyproc WallBoard each side of timber studs at 600mm centres, with ISOVER APR 1200 within the cavity.

Method of Compliance: Tested

Insulation thickness (mm)	Timber Stud Thickness (mm)	Lab sound insulation 100-3150 Hz, R_w dB	Fire resistance (mins)
65	63	40	30

A partition wall constructed from 1 layer of 12.5mm Gyproc WallBoard_{TEN} each side of timber studs at 600mm centres, with ISOVER APR 1200 within the cavity.

Method of Compliance: As described in Approved Document E

Insulation thickness (mm)	Timber Stud Thickness (mm)	Lab sound insulation 100-3150 Hz, R_w dB	Fire resistance (mins)
25	75	40	30

Metal Stud Partitions

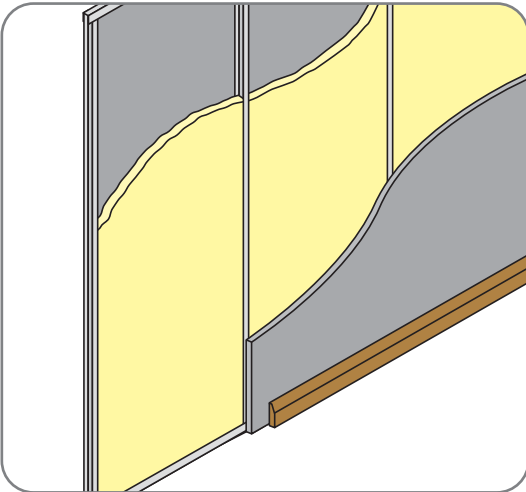

1 layer of 12.5mm Gyproc WallBoard each side of GypFrame metal studs at 600mm centres with ISOVER APR 1200 within the cavity.

Method of Compliance: Tested

Insulation thickness (mm)	Lab sound insulation 100-3150 Hz, R_w dB	Fire resistance (mins)
25	40	30
50	42	30

Acoustic Performance

Party Walls

Part E Building Regulations July 2003 calls for a minimum 45dB airborne sound insulation in party walls (plus additional Ctr correction factor for low frequency noise). The following construction incorporating ISOVER APR 1200 will comply with this requirement as a Robust Detail.

Twin Timber Frames with or without cavity sheathing board

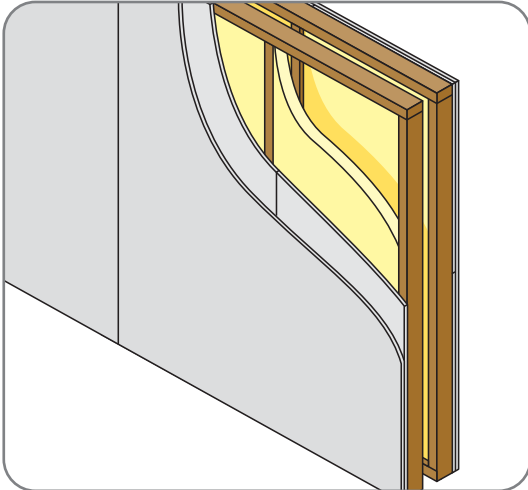

2 layers of plasterboard nominally 22Kg/m² (typically 19mm Gyproc Plank plus 12.5mm Gyproc WallBoard) with joints staggered, each side of twin timber frames with a minimum of 65mm ISOVER APR 1200 in each frame.

Unsheathed Construction

Method of compliance: Robust Detail

Insulation thickness (mm)	Robust Detail	Test Performance Range dB	Mean Performance Range dB
65	E-WT-1	47 - 65	55

Sheathed Construction

Method of compliance: Robust Detail

Insulation thickness (mm)	Robust Detail	Test Performance Range dB	Mean Performance Range dB
65	E-WT-2	48 - 64	54

Renovation

The solution detailed below is a practical upgrading solution for existing walls that provides a high level of acoustic improvement in conversion work.

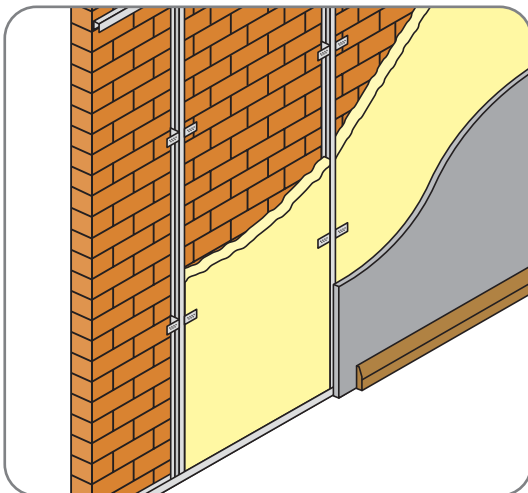

103mm brick wall with 13mm plaster on each side lined on one side with 1 layer of 12.5mm Gyproc SoundBloc board fixed to Gyproc GyLiner metal frame system (35mm gap from wall) and 25mm ISOVER APR 1200 within the cavity.

Insulation thickness (mm)	Lab sound insulation 100-3150 Hz (Improvement over existing wall shown in brackets) R _w dB	R _w + Ctr (dB)
25	57 (10)	50

Acoustic Performance

Internal Floors in New Dwellings

Internal floors within the same dwelling need to achieve 40dB airborne sound insulation. Solutions can be either supported by laboratory test reports or contained within Approved Document E (to comply with Part E Building Regulations, July 2003 England and Wales). The following floor constructions meet this requirement.

Engineered I-joist Floor

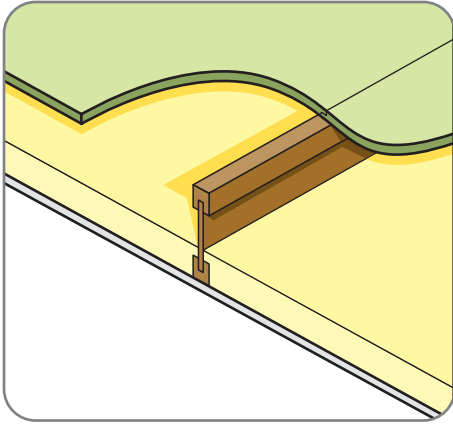

Timber floor consisting of engineered I-joists nominally 240mm deep and at 600mm centres, with a screw-fixed walking surface of 22mm t & g chipboard, and with a ceiling finish of 15mm Gyproc WallBoard screw-fixed directly to the joists. A 65mm thickness of ISOVER APR 1200 laid on top of the plasterboard ceiling.

Method of compliance: Tested

Insulation thickness (mm)	Lab sound insulation 100-3150 Hz, R _w dB
65	40

Timber joist Floor

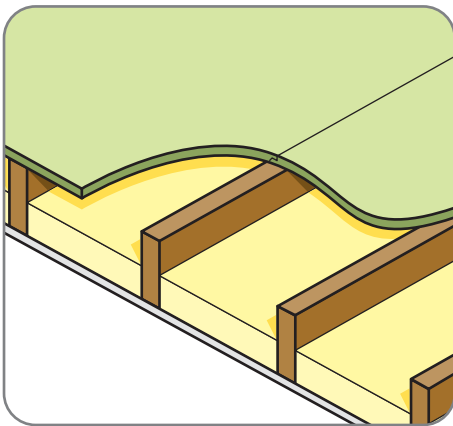

Timber floor consisting of 200mm x 50mm timber joists, with an 18mm t & g chipboard walking surface, and with 12.5mm Gyproc WallBoard TEN ceiling. APR 1200 to a minimum 100mm thickness in the floor void.

Method of compliance: As described in Approved Document E

Party Floors in New Dwellings

Party separating floors between dwellings are required under Part E of the Building Regulations to achieve a minimum 45dB (plus additional Ctr correction factor for low frequency noise) airborne sound insulation. In addition, party floors need to have a maximum 62dB impact sound insulation. The following floor, incorporating ISOVER APR 1200 acoustic insulation is approved Robust Detail E-FT-1.

TIMBER I-JOIST FLOOR E-FT-1 (FOR USE WITH TIMBER FRAME WALLS ONLY)

Using ceiling treatment CT2

- 18mm (min) T&G flooring board
- 19mm Gyproc plank
- 25mm (min) ISOVER APR 1200 between flooring battens**
- FFT-1 resilient composite deep battens (may have resilient layer at the top or the bottom)
- 15mm (min) floor decking
- 100mm (min) ISOVER APR 1200**
- Gyplframe RB1 resilient bar at 400mm centres
- 2 layers 15mm Gyproc WallBoard
- 240mm (min) timber I-joists

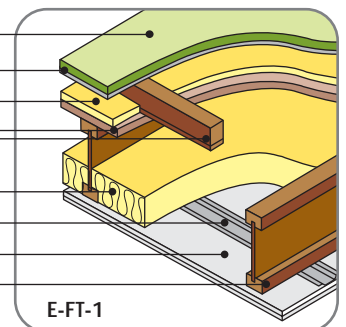

E-FT-1

Fire Performance

Made from inherently non-combustible materials, ISOVER APR 1200 is completely fire safe, achieving a Euroclass A1 fire rating when classified in accordance with BS EN 13501-1.

The following constructions show the fire resistance for imperforated partitions using Gyproc metal partitioning with ISOVER APR 1200 in the cavity.

Internal Partitions

60 minutes

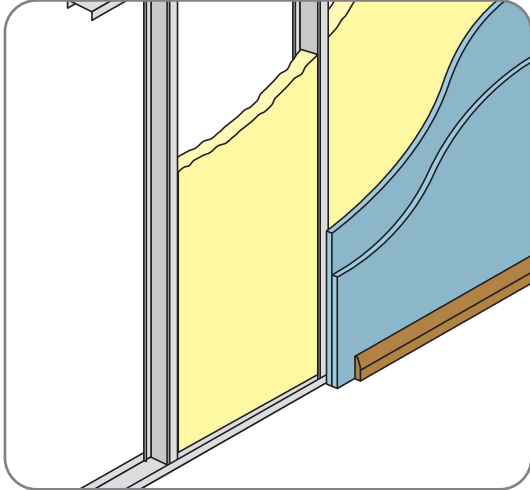

Two layers of Gyproc SoundBloc board (2x12.5mm) each side of 92mm Gyproc metal studs at 600mm centres plus 90mm ISOVER APR 1200 in the cavity.

Insulation thickness (mm)	Fire resistance (mins)	Lab sound insulation 100-3150 Hz, R _w dB
90	60	56

Performance substantiation report A206235

90 minutes

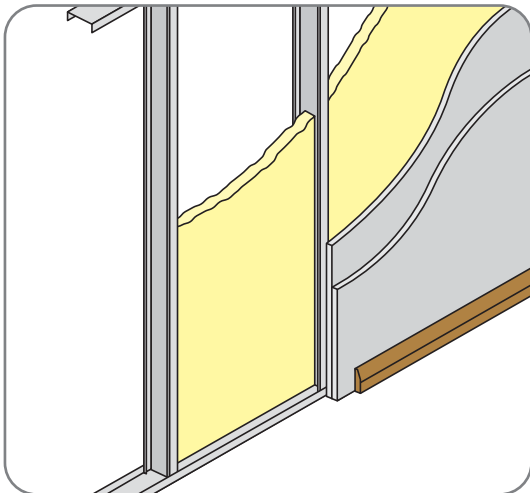

Two layers of Gyproc WallBoard (2x15mm) each side of 146mm Gyproc studs at 600mm centres plus 50mm ISOVER APR 1200 in the cavity.

Insulation thickness (mm)	Fire resistance (mins)	Lab sound insulation 100-3150 Hz, R _w dB
50	90	51

Performance substantiation report A206150

120 minutes

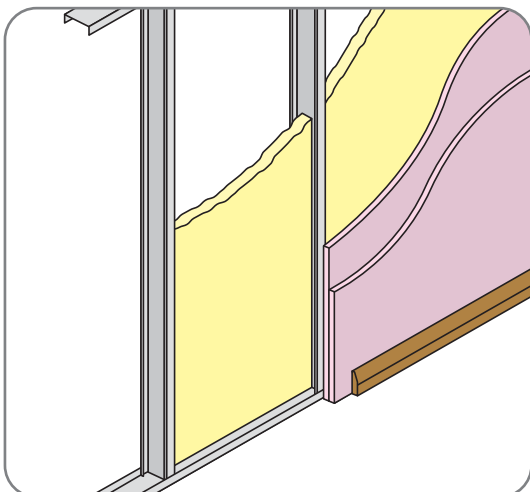

Two layers of Gyproc FireLine board (2x12.5mm) each side of 146mm Gyproc studs at 600mm centres plus 50mm ISOVER APR 1200 in the cavity.

Insulation thickness (mm)	Fire resistance (mins)	Lab sound insulation 100-3150 Hz, R _w dB
50	120	51

Performance substantiation report A206151

Thermal Performance

Thickness (mm)	R-value (m ² K/W)
25	0.64
50	1.22
65	1.59
90	2.09
100	2.33
140	3.26

Packaging and Physical Dimensions



Thickness (mm)	Width (mm)	Length (m)	Pack area (m ²)
25	2x600	20.00	24.00
50	2x600	13.00	15.60
65	2x600	10.00	12.00
90	2x600	10.19	12.23
100	2x600	9.17	10.64
140	2x600	6.55	7.86

ISOVER APR 1200 is manufactured in roll form in a single thickness. The rolls are compression packed in individual packs using a strong polythene packaging film. The packs are then stacked on wooden pallets with final weatherproof outer covering, giving the option of outside storage.



Technical Support: 0115 945 1143 or E-mail isover.enquiries@saint-gobain.com

General Enquiries: British Gypsum-Isover, East Leake, Loughborough, Leicestershire LE12 6JU Tel: 0115 945 1050 Fax: 0115 945 1915
British Gypsum-Isover Limited reserve the right to alter or amend product specification without notice. The information given in this publication is correct to the best of our knowledge at the time of publication. Whilst British Gypsum-Isover Limited will endeavour to ensure publications are up to date, it is the users responsibility to check with us that it is correct prior to use.